



Standard Test Method for Measuring Solution Viscosity of Polymers with a Differential Viscometer¹

This standard is issued under the fixed designation D5225; the number immediately following the designation indicates the year of original adoption or, in the case of revision, the year of last revision. A number in parentheses indicates the year of last reapproval. A superscript epsilon (ϵ) indicates an editorial change since the last revision or reapproval.

1. Scope*

1.1 This test method covers the determination of the solution viscosity of polymers using a differential or the modified differential viscometer. It is applicable to all polymers that dissolve completely without chemical reaction or degradation to form solutions that are stable with time and temperature. Results of the test are usually expressed as specific viscosity, intrinsic viscosity (limiting viscosity number), inherent viscosity (logarithmic viscosity number), or relative viscosity (viscosity ratio).

1.2 Since there is more than one type of viscometer available to measure a differential pressure, follow the manufacturer's directions applicable to the equipment being used.

1.3 The solution viscosity values are comparable with those obtained using a glass capillary of Test Method D2857. This test method differs from the glass capillary in that the solvent and the solution are compared at the same time that a test is run. With a glass capillary, each solution must be referenced back to the solvent run in the same capillary at the same temperature.

1.4 The values stated in SI units are to be regarded as standard. No other units of measurement are included in this standard.

1.5 *This standard does not purport to address all of the safety concerns, if any, associated with its use. It is the responsibility of the user of this standard to establish appropriate safety and health practices and determine the applicability of regulatory limitations prior to use.* For specific hazard statements, see Section 8.

NOTE 1—There is no known ISO equivalent to this standard.

¹ This test method is under the jurisdiction of ASTM Committee D20 on Plastics and is the direct responsibility of Subcommittee D20.70 on Analytical Methods.

Current edition approved May 1, 2014. Published June 2014. Originally approved in 1992. Last previous edition approved in 2009 as D5225 - 09. DOI: 10.1520/D5225-14.

2. Referenced Documents

2.1 *ASTM Standards*:²

D1243 Test Method for Dilute Solution Viscosity of Vinyl Chloride Polymers

D2857 Practice for Dilute Solution Viscosity of Polymers

E691 Practice for Conducting an Interlaboratory Study to Determine the Precision of a Test Method

3. Terminology

3.1 *Definitions*:

3.1.1 *inherent viscosity*—the ratio of the natural logarithm of the relative viscosity to the concentration. The IUPAC term for inherent viscosity is *logarithmic viscosity number*.

3.1.2 *intrinsic viscosity*—limit of the reduced and inherent viscosities as the concentration of the polymeric solute approaches zero and represents the capacity of the polymer to increase viscosity. The IUPAC term for intrinsic viscosity is *limiting viscosity number*.

3.1.3 *reduced viscosity*—the ratio of the specific viscosity to the concentration. Reduced viscosity is a measure of the specific capacity of the polymer to increase the relative viscosity. The IUPAC term for reduced viscosity is *viscosity number*.

3.1.4 *relative viscosity*—the ratio of the polymer solution pressure to the pressure of the solvent.

3.1.5 *specific viscosity*—the relative viscosity minus one.

3.1.6 *viscosity constant, K*—baseline reading when solvent is present in both capillaries.

4. Summary of Test Method

4.1 *Differential Viscometer (Fig. 1)*:

² For referenced ASTM standards, visit the ASTM website, www.astm.org, or contact ASTM Customer Service at service@astm.org. For *Annual Book of ASTM Standards* volume information, refer to the standard's Document Summary page on the ASTM website.

*A Summary of Changes section appears at the end of this standard

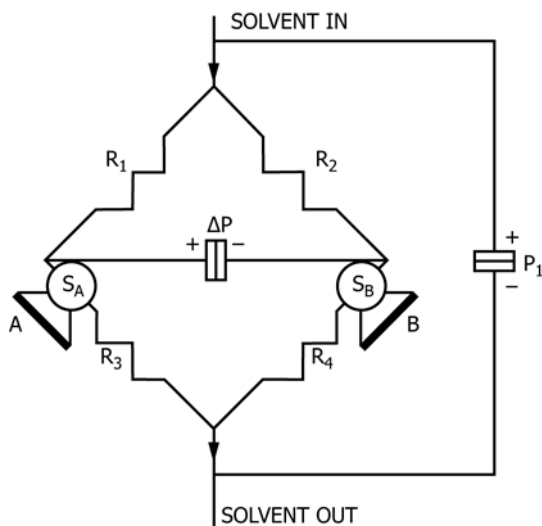

NOTE 1—

R₁, R₂, R₃, R₄ = Matched SS Capillary Tubing

A, B = Solution Holdup Reservoirs

S_A, S_B = Switching Valve

P_i = Solvent Inlet Pressure Transducer

ΔP = Differential Pressure Transducer

FIG. 1 Differential Viscometer

4.1.1 The viscosity measurement with the differential viscometer is based on a fluid analog of the Wheatstone Bridge. Pure solvent at constant inlet pressure P_i enters a balanced capillary network and flows through, producing a zero or baseline pressure on the differential pressure transducer. Solution is loaded into the sample reservoir A and then injected onstream by means of the switching valve S_A . The differential pressure begins to rise until it reaches a steady state value of ΔP proportional to the specific viscosity of the solution. The differential pressure is monitored continuously on a strip chart recorder or computer, providing a baseline where ΔP is measured. The equation relating ΔP to specific viscosity is:

$$\eta_{sp} = \frac{4\Delta P}{P_i - 2\Delta P} \quad (1)$$

4.1.2 Derivation of the equation is in Annex A1.

4.2 Modified Differential Viscometer (Fig. 2):

4.2.1 The modified differential viscometer has two stainless steel capillaries connected in series with a sample loading/injection valve before the second capillary. Two differential pressure transducers, P_1 and P_2 , are connected in parallel

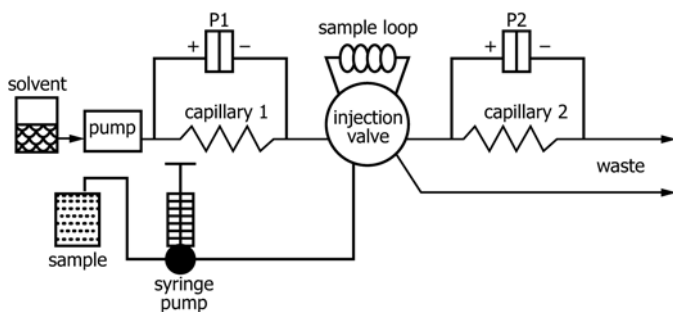

FIG. 2 Relative Viscometer

across the capillaries. A pump continuously supplies solvent flow. The ratio of the pressures P_2 and P_1 is proportional to the ratio of the viscosities of the fluid in capillary 2 to that in capillary 1.

$$\frac{P_2}{P_1} = K \frac{\eta_2}{\eta_1} = K \cdot \text{Relative Viscosity} \quad (2)$$

4.2.1.1 K , the viscosity constant, is obtained from the baseline reading when solvent is present in both capillaries, so η_2/η_1 is unity.

4.2.1.2 With the valve in LOAD position, the sample is flushed through the sample loop by the syringe pump. A baseline reading is established and recorded by the computer data acquisition system. When the valve is switched to the INJECT position, solvent flowing from capillary 1 pushes the sample into capillary 2. The differential pressure P_2 will increase due to the higher viscosity of the sample solution. The steady state value of P_2/P_1 then yields the value of relative viscosity of the sample.

$$\text{Relative Viscosity} = \frac{P_2}{KP_1} \quad (3)$$

4.2.1.3 Absolute viscosity of the sample may be calculated from relative viscosity, RV , assuming the viscosity of the solvent is known.

$$\eta(\text{sample}) = RV \cdot \eta(\text{solvent}) \quad (4)$$

5. Significance and Use

5.1 Solution viscosity values for polymers are related to the average molecular size of that portion of the polymer which dissolves in the solvent.

6. Apparatus

6.1 *Differential Viscometer, or Relative Viscometer, Dilute Solution Viscosity (DSV) System,*

6.2 *Glass Vial, 25 mL,*

6.3 *Screw Type Cap, open top, size 24-400,*

6.4 *Septa, aluminum foil (household grade) or acceptable substitute,*

6.5 *Balance, accurate to 1.0 ± 0.1 mg,*

6.6 *Filter Funnel, and*

6.7 *Filter medium, coarse filter paper or metal screen of 140 mesh or finer.*

7. Reagents and Materials

7.1 *Polymer Sample.*

7.2 *Solvent.*

7.3 *Compressed Gas Cylinder of nitrogen or helium.*

8. Hazards

8.1 Flammable solvents are to be used in a hood or a well ventilated area.

8.2 Solvents are to be dated and to be used on a first-in first-out basis.